

FRONT VIEW

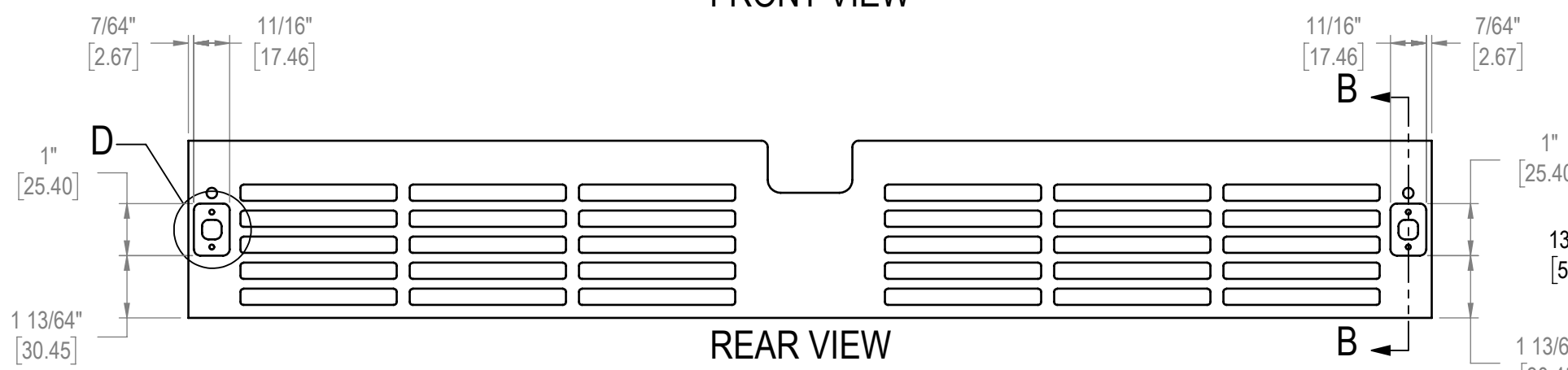

REAR VIEW

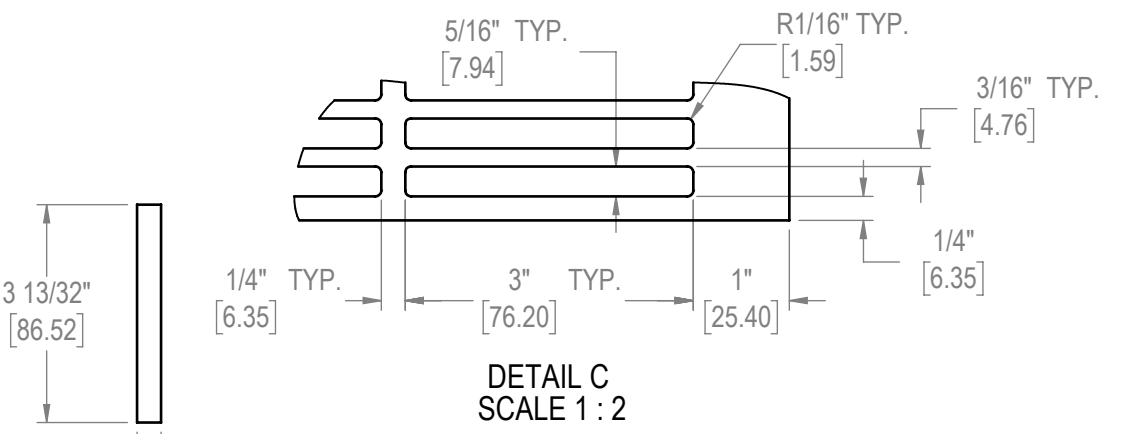

DETAIL C  
SCALE 1 : 2

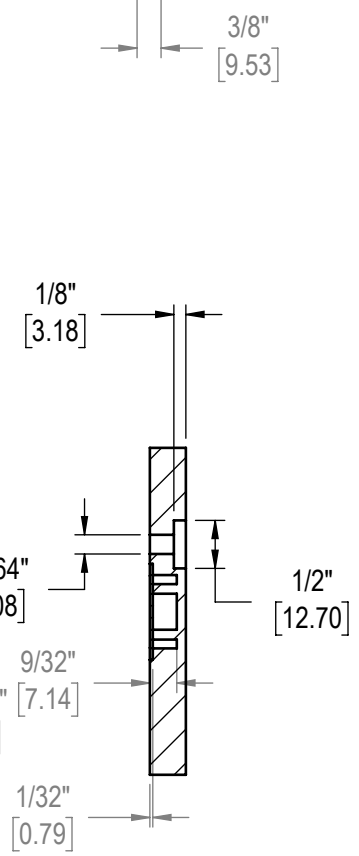

SECTION B-B  
SCALE 1 : 2

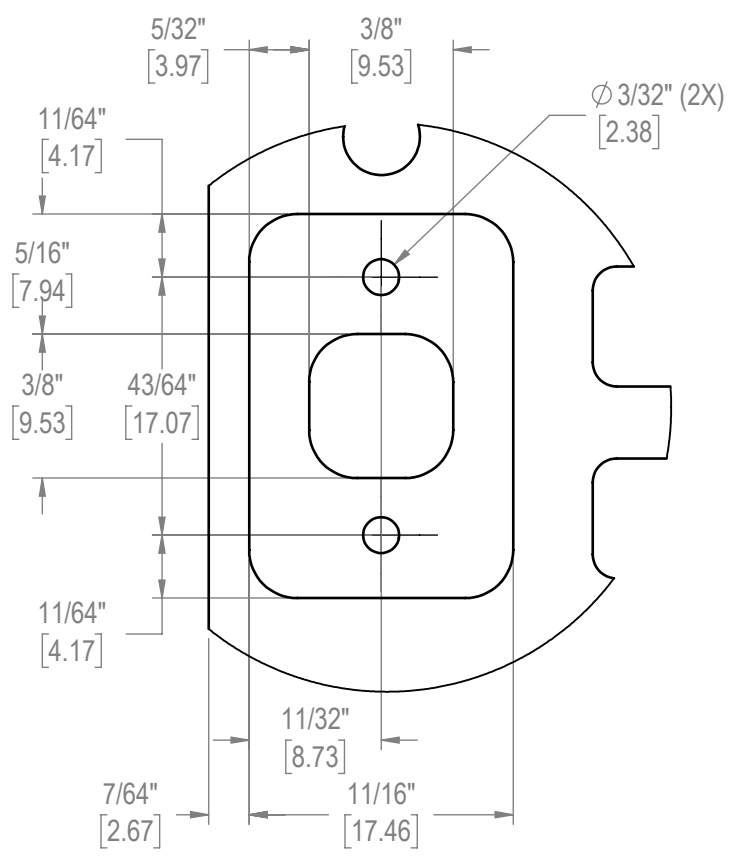

DETAIL D  
SCALE 2 : 1

NOTE: GRILL SHOWN ON THIS PAGE IS FOR EITHER A SINGLE STAND ALONE UNIT OR THE BOTTOM UNIT OF A STACKED CONFIGURATION

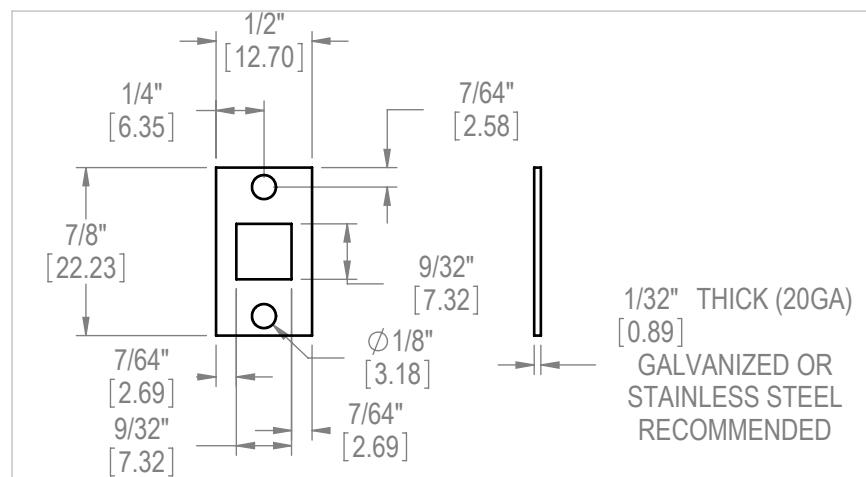

METAL CLIP REQUIRED FOR SNAP IN RETAINER THAT ASSEMBLES GRILL TO THE UNIT. THIS CLIP MUST BE SCREWED TO THE GRILL USING THE FEATURES SHOWN IN DETAIL VIEW "D"

NOTE: ALL INTERNAL RADII ARE 1/8IN UNLESS OTHERWISE SPECIFIED

REV.	DESCRIPTION	DATE	APPROVED
A	INITIAL RELEASE	07/09/2021	CJK

REVISIONS			
<b>Perlick Corporation</b> Milwaukee, Wisconsin			
<b>GRILL, WOOD, WITH HOLES FOR 24" RESIDENTIAL CABINET</b>			
REFERENCE: 68904	PART NO.	DWG NO.	
	<b>1031515-1A</b>	<b>1031515</b>	
PURCHASE REC.:	SCALE = 1:3	SHEET 2 OF 9	

MATERIAL: WOOD	SIGNATURES DRAWN BY: CJK APPVD BY: CJK	DATE 07/12/2021 07/09/2021
QTY.: -	UNLESS OTHERWISE SPECIFIED: DIMENSIONS ARE IN INCHES TOLERANCES: Ang = ±1.0° Frac. = ±1/16	
FINISH:	BREAK SHARP EDGES - .015 X 45° RADIUS SHARP FILLETS - .015 TO .031 HOLES: Ø .1260 THRU Ø .125: ±.004 Ø .2510 THRU Ø .500: ±.006 Ø .5010 THRU Ø .750: ±.008 Ø .7510 THRU Ø 1.000: ±.010 Ø 1.001 & UP: ±.012	

THIS DOCUMENT / PUBLICATION / SOFTWARE / DRAWING CONTAINS PROPRIETARY INFORMATION WHICH IS THE PROPERTY OF THE PERLICK CORPORATION. IT MAY NOT BE REPRODUCED OR TRANSMITTED IN ANY FORM, ELECTRONIC OR MECHANICAL, INCLUDING PHOTOCOPYING, RECORDING, OR USED IN ANY INFORMATION STORAGE, TRANSMISSION, OR RETRIEVAL SYSTEM, WITHOUT WRITTEN PERMISSION FROM THE PERLICK CORPORATION. COPYRIGHT 2015 PERLICK CORPORATION. ALL RIGHTS RESERVED.